

TECHNICAL DATA

VT06

100nm RADFET

in 8L Side Braze Ceramic package

For doses between 1Gy (100rad) and 10kGy (1Mrad)

VT06 Description and Pin-Out

The VT06 is Varadis 100nm RADFET chip packaged in a 8 lead ceramic side braze package. The part consists of two RADFETs and one diode (see Figure 1 and Table 1). There are two RADFETs with a W/L of 300 μ m/50 μ m (one with all four terminals accessible – R1, and another with gate/drain as well as source/bulk tied together – R2). The cathode of the diode is tied to the bulk of the RADFETs, while the anode is accessible via pin 5.

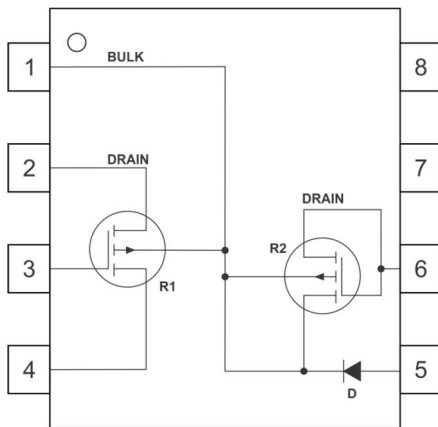

Figure 1: VT06 pin-out drawing.

Table 1: VT06 pin-out description.

Pin Number	Description
1	Bulk (common)
2	Drain of R1
3	Gate of R1
4	Source of R1
5	Diode Anode ¹
6	Gate/Drain of R2
7	Not connected
8	Not connected

Maximum Ratings

Maximum ratings of the VT06 RADFET are given in Table 2.

Table 2: Maximum ratings of the VT06. Measured at room temperature.

Characteristics	Symbol	Specification	Unit	Remarks
Drain-Source Voltage	V_{DS}	-40	V	
Gate-Source Voltage	V_{GS}	± 80	V	
Drain-Gate Voltage	V_{DG}	± 80	V	
Drain Current	I_D	-1	mA	Continuous
Source Current	I_S	-1	mA	Continuous
Temperature Endurance Range	T_{ER}	-55 to +125	$^{\circ}C$	
Maximum sensitivity	S_{MAX}	2.9	mV/Gy	

¹ More information about the purpose of the on-chip diode you can find in the notes section

Modes of Operation

Irradiation Mode (Sense Mode)

In this mode of operation, it is recommended that all terminals of the RADFET are connected to ground. For alternative biasing options, contact the manufacturer.

Read-Out Mode (Accumulated Radiation Dose Read-Out)

The RADFET can be read at arbitrary intervals, depending on the application. The period between readings can be from seconds to days or even months. The circuit used to read out the RADFET (Reader Circuit - RC) is shown in Figure 2 with connection configuration in Table 3.

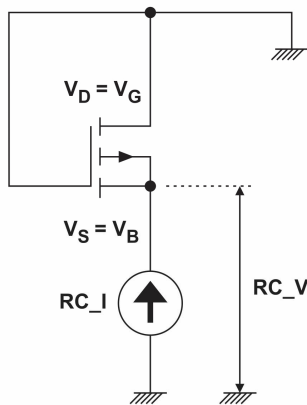

Table 3: Connections in Read-Out mode.

Terminal	Bias
S=B	Current is forced (RC_I) Voltage reading is taken (RC_V)
G=D	0V (common)

Figure 2: Reader Circuit (RC) configuration.

Current RC_I is forced into the RADFET, connected in RC configuration (Figure 2). The voltage at the source (RC_V) is measured; this voltage is called “RC threshold voltage”. Typical I-V curves at different temperatures for un-irradiated device in this configuration are shown in Figure 3. In principle, any read-out current (RC_I) value above $5 \mu\text{A}$ can be chosen, if the value is kept unchanged after the start of radiation exposure. For best temperature compensation, the RC_I value of $17 \mu\text{A}$ is recommended where the temperature influence is minimal.

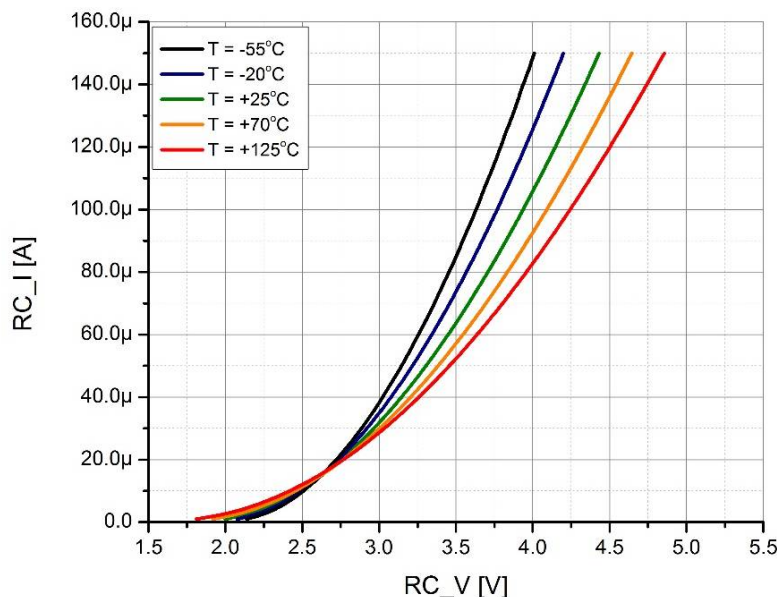

Figure 3: Typical Reader Circuit (RC) I-V curves, pre-irradiation. Measured at different temperatures.

Electrical Parameters

The most important electrical parameter of un-irradiated RADFET is RC threshold voltage (RC_V). Specification for RC_V is given in Table 4. Results of RC_V measurements prior to shipment are included in documentation that comes with ordered parts. Typically, the range of RC_V of delivered parts is significantly tighter than in the specification.

Table 4: Specification for RC threshold voltage. Measured at room temperature.

Parameter	Symbol	Test Circuit and Conditions	Limits		Unit
			Min	Max	
RC Threshold Voltage	RC_V	Figure 2 and Table 3 RC_I = 17 μ A	2.1	3.5	V

Calibration Data

The calibration curve for the RADFET shows evolution of ΔV (the change in RC threshold voltage with reference to its pre-irradiation value) with dose. Note that a specific calibration curve, obtained using the X-ray source, is associated with each RADFET production batch. The calibration curve, together with analytical equation and fitting coefficients, will be provided with the supplied parts. For illustration, typical calibration curve is shown in Figure 4.

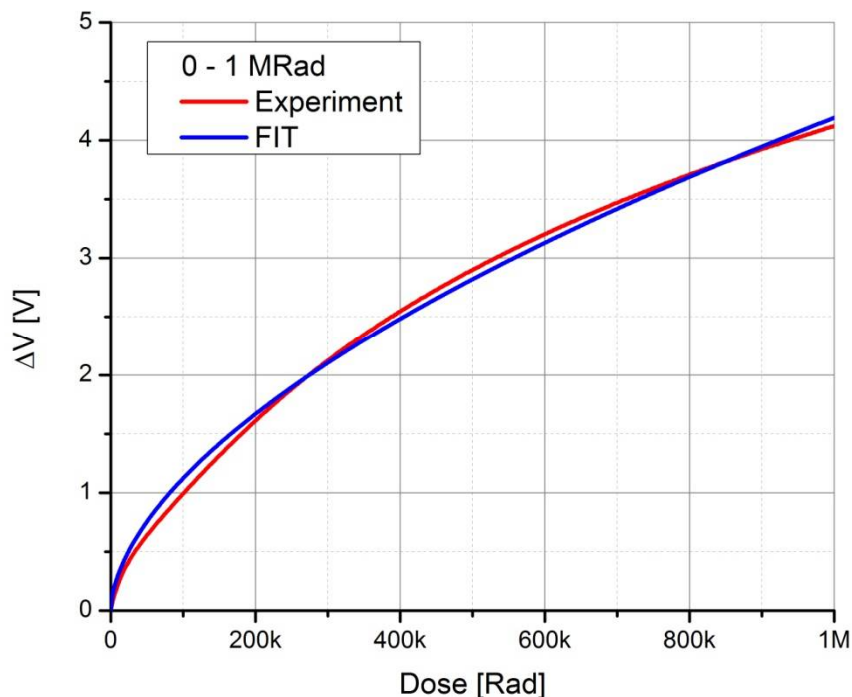

Figure 4: Calibration curve indicating change in RC_V during irradiation. Irradiation at room temperature with photon source, dose rate ~500 Gy/h (50 krad/h). Voltage measurements performed at room temperature using 0.2% duty cycle with all terminals grounded between measurements

Package Information

VT06 package specifications are given in Table 5, and package diagram in Figure 5.

Table 5: VT06 package specifications.

Description	Specification
Package Type	8-pin side braze ceramic package with kovar lid
Package Dimensions (L x W x H)	10.21mm x 7.87mm x 3.05mm (see Figure 5)

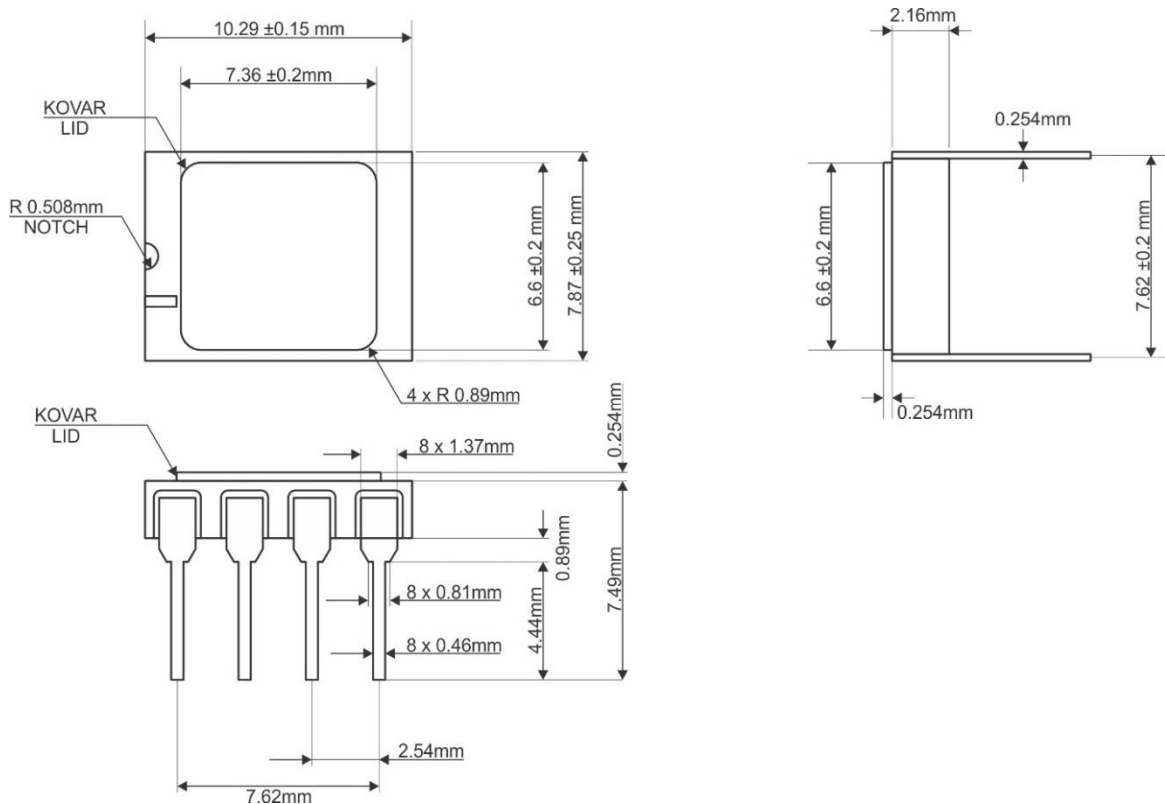

Figure 5: VT06 package diagram.

Recommended dimensions for solder pad layout are given Figure 6.

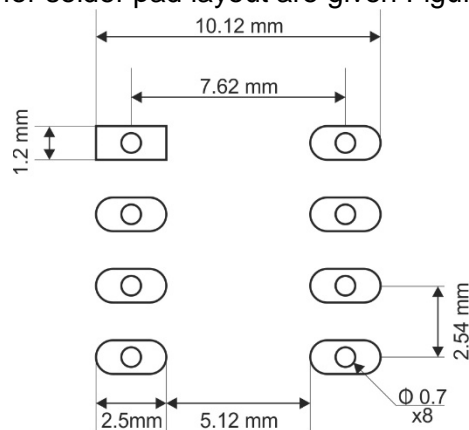

Figure 6: Recommended solder pad layout. Dimensions are inclusive of plating.

Handling

Our RADFETs undergo 100% electrical test and visual inspection immediately prior to shipment. Therefore, all parts should reach the customer in excellent condition. To ensure that the RADFETs remain in this condition, please handle the parts as carefully as possible and observe standard precautions related to ESD sensitive devices.

Soldering

For our RADFETs we strongly recommend hand soldering onto printed circuit boards prior to exposure in radiation field. The temperature used in the soldering should be as low as possible using low-temperature melting point solder alloys. It is a good practice to solder the pins individually with 10sec break between pins, this will prevent overheating of the RADFET die and allow the heat generated from the soldering to dissipate.

It is important that the RADFET is the last component to be soldered onto a circuit board. If different soldering method is required, please contact us at support@varadis.com.

We usually calibrate our ceramic packaged components using test fixtures without soldering onto printed circuit boards, if soldering is required by the customer, please follow the above instructions.

Notes

This product was calibrated at room temperature using accelerator X-ray source. Irradiation is performed in a single event at the dose rate of ~500 Gy/hour (50 krad/hour) and includes the dose range from 10–10k Gy (1 krad – 1 Mrad).

Customers whose requirements include conditions significantly different from the above should contact support@varadis.com to discuss the optimum way to implement the RADFETs for their specific applications.

The VT06 has a large dynamic range, from 10 Gy (1 krad) to 10 kGy (1 Mrad).

While the supplied calibration curve covers doses from 10–10,000 Gy, other measurements at room temperature show that lower doses, down to 1Gy, can be detected. The lower the minimum dose required by the customer, the more accurate must be the RADFET temperature compensation and read-out electronics. Please contact support@varadis.com for further details if your application includes lower dose range.

Regarding the high end of the dose range, VT06 can measure doses even higher than 10 kGy (1 Mrad). However, the sensitivity decreases with dose and it depends on the actual application requirements whether this sensitivity loss is acceptable. As VT06 comes calibrated up to 10 kGy (1 Mrad), additional calibration is needed for measurements beyond this limit.

The on-chip diode is connected between pin 5 (anode) and pin 1 (cathode). The diode is not sensitive to ionizing radiation in the way the RADFETs are. The diode can be used as an indicator of the chip temperature during irradiation (sense mode) only.

During RADFET irradiation (sense mode) the diode can be forward biased by forcing positive current into pin1 and the diode voltage obtained at the same pin. It is recommended that after diode forward bias, pin1 is connected back to the ground or remain floating.

During RADFET read-out mode (accumulated radiation dose read-out) the diode **must not** be forward biased as it will influence the RADFET readout voltage and disturb the measurement.

For diode response over a temperature range, and other queries related to this document please contact support@varadis.com.